

Yamaha Motor's First Motorcycle

YA-1

Assembly Instructions

Special Edition

pack 3



Front Tire, Rear Tire, Full Model Assembly Instructions



Please follow these assembly instructions, cross-checking the part numbers on the parts sheet. Assemble all the parts from **pack 1** to **pack 3**.

A realistic recreation of the **YA-1**. will be the result.

This file provides assembly instructions. Please download the parts data separately.



We recommend to print out the parts data on A4 inkjet printer paper for paper craft, sturdy paper or card.

1 To begin

Tools and materials needed

-Ruler - scissors - blade cutter or "Exacto-knife" - awl or other pointed tool - Embosspen - Transer (for making a folding crease) - Felt pen - pin set - Glue - Hand towel (for cleaning your fingers) - string - dictionary or other heavy book(to press the papers flat).

Items of Caution

*Take care when using sharp or pointed objects or when using bladed cutting tools. Place a heavy sheet of paper under the paper you want to cut.

*Use glue and other adhesives only in well-ventilated areas.

*When printing, use a slightly reduced font size. There may be differences in dimensions, depending on the type of printer used.

2 How to assemble

*Follow the working method and markings carefully.

*Cut carefully along the outer line with cutting blade, Exacto-knife or scissors.

One-point Advise

*Cut carefully with cutting blade, Exacto-knife or scissors.

*For folding parts, first use an awl or other pointed tool to make a light crease along the dotted or solid line. This will make the folds straight. Avoid making strong creases, as this will cause the paper to tear.

*As an adhesive, white wood glue is recommended. Avoid over application as this may cause the paper to wrinkle.

*Before beginning assembly, test adhesive amounts on extra paper.

*Occasionally, white spots will be apparent on folds and cuts. Use a marker or pencil to fill in these spots.

It is recommended that this be done after each stage of assembly because coloring becomes more difficult once parts are assembled.

Basic working method and markings

Solid lines

Fold along these lines.

The printed surface should be on the outside of the folded shape.

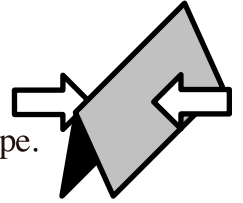

Broken lines

Fold along these lines.

The printed surface should be on the inside of the folded shape.

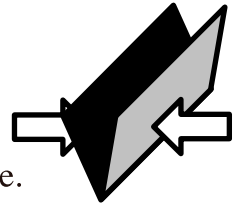

Dotted lines

Cut along these lines.

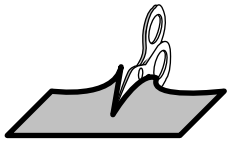

Do not fold or cut the parts marked X.

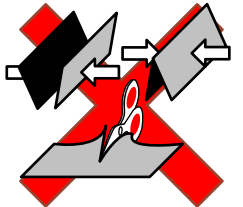

Cut out parts marked with an asterisk(*).

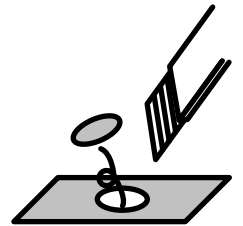

Red dots are the reference positions for gluing surfaces.

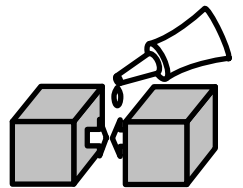

Please glue them by aligning the red and red/blue and blue parts if they are marked on the paper.

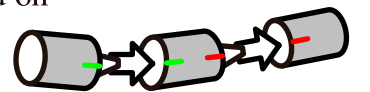

These shaded areas indicate where glue should be applied.

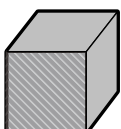

3 Assembly of the Front Tire Spoke

Please refer to the "Basic working method and markings" symbol chart on Page 2 to assemble each part.



Front Tire Spoke

Glue in order from 1 to 4 on the graphic.

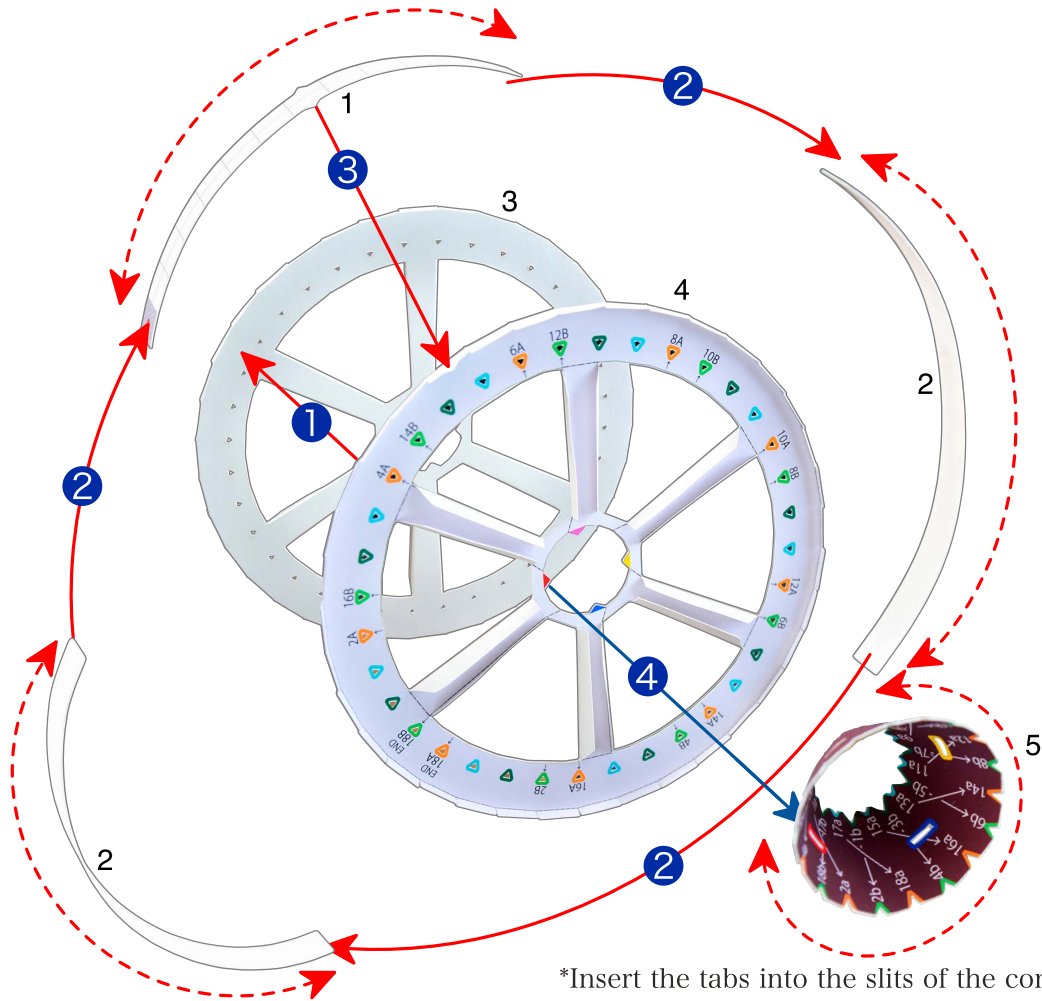

Front Brake

Glue in order from 1 to 3 on the graphic.

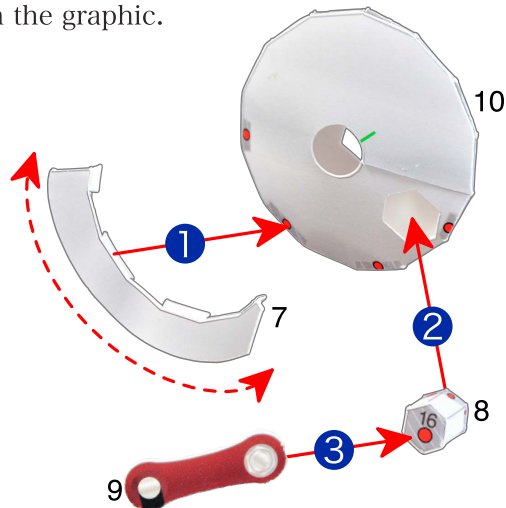

Please refer to the “Basic working method and markings” symbol chart on Page 2 to assemble each part.



Assembly of Spokes - 1 (Section A)

Tie a string to Hole 1A in the front tire spoke. Lace the string through the spindle via Gutter 1a of the spindle, hook it at Gutter 2a to lace through Holes 2A then 3A. Bring the string to Gutter 3a and lace it through the spindle to Gutter 4a. Repeat this procedure until the string reaches Hole 18A. Tie the string there.

*When you complete Section A, assemble Section B in the same manner.

*String(e.g. an embroidery thread) A couple of approx. 1.5m strings per wheel.

Movie: How to assemble the spokes for the special edition



Lacing Procedure for Section A

1A→1a→2a→2A→3A→3a→4a→4A→5A→
5a→6a→6A→7A→7a→8a→8A→9A→9a→
10a→10A→11A→11a→12a→12A→13A→
13a→14a→14A→15A→15a→16a→16A→
17A→17a→18a→18A

Lacing Procedure for Section B

1B→1b→2b→2B→3B→3b→4b→4B→5B→
5b→6b→6B→7B→7b→8b→8B→9B→9b→
10b→10B→11B→11b→12b→12B→13B→
13b→14b→14B→15B→15b→16b→16B→
17B→17b→18b→18B

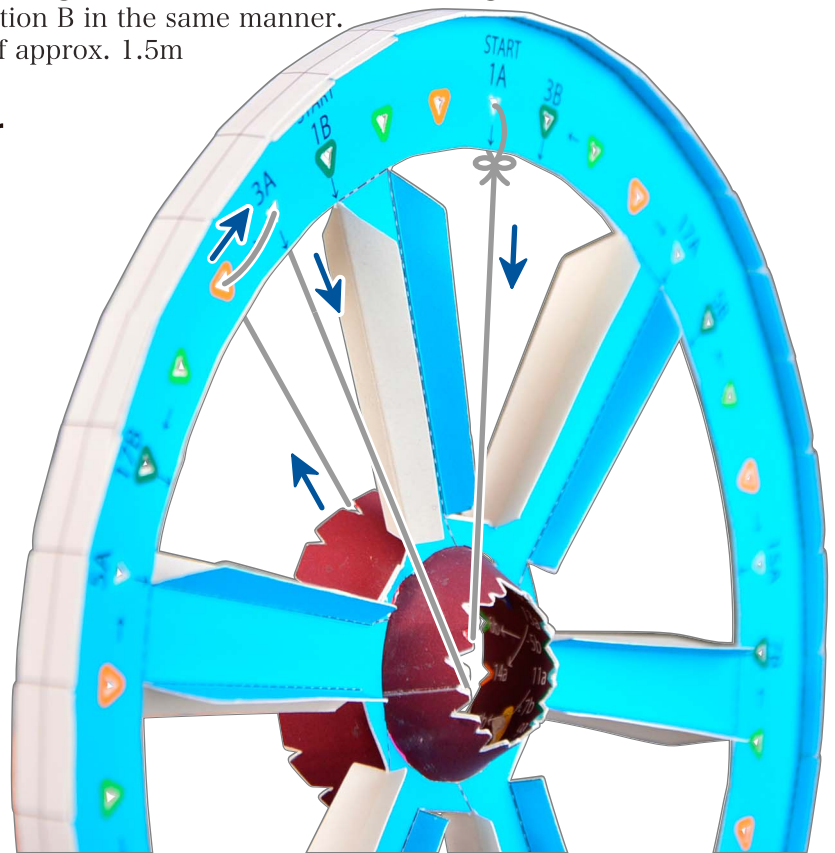

Assembly of Spokes - 2

Once you complete the lacing of Sections A and B, detach the post of the front tire spoke.

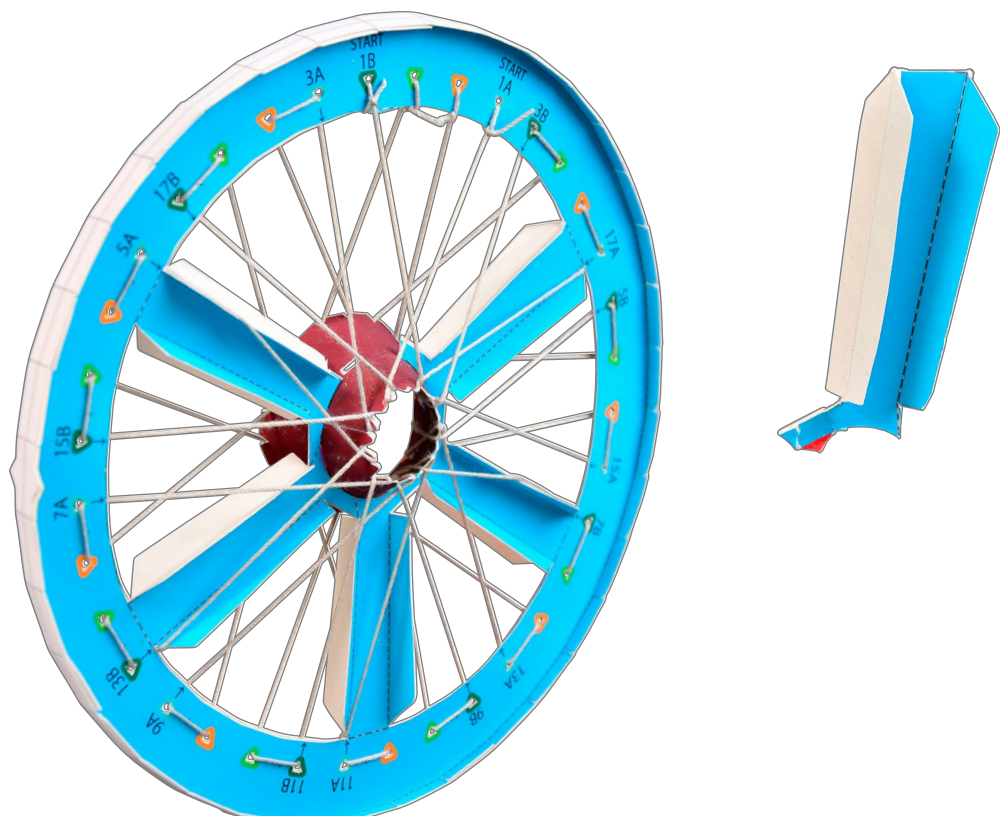

3 Assembly of the Front Tire

Please refer to the "Basic working method and markings" symbol chart on Page 2 to assemble each part.



Glue in order from 1 to 7 on the graphic.

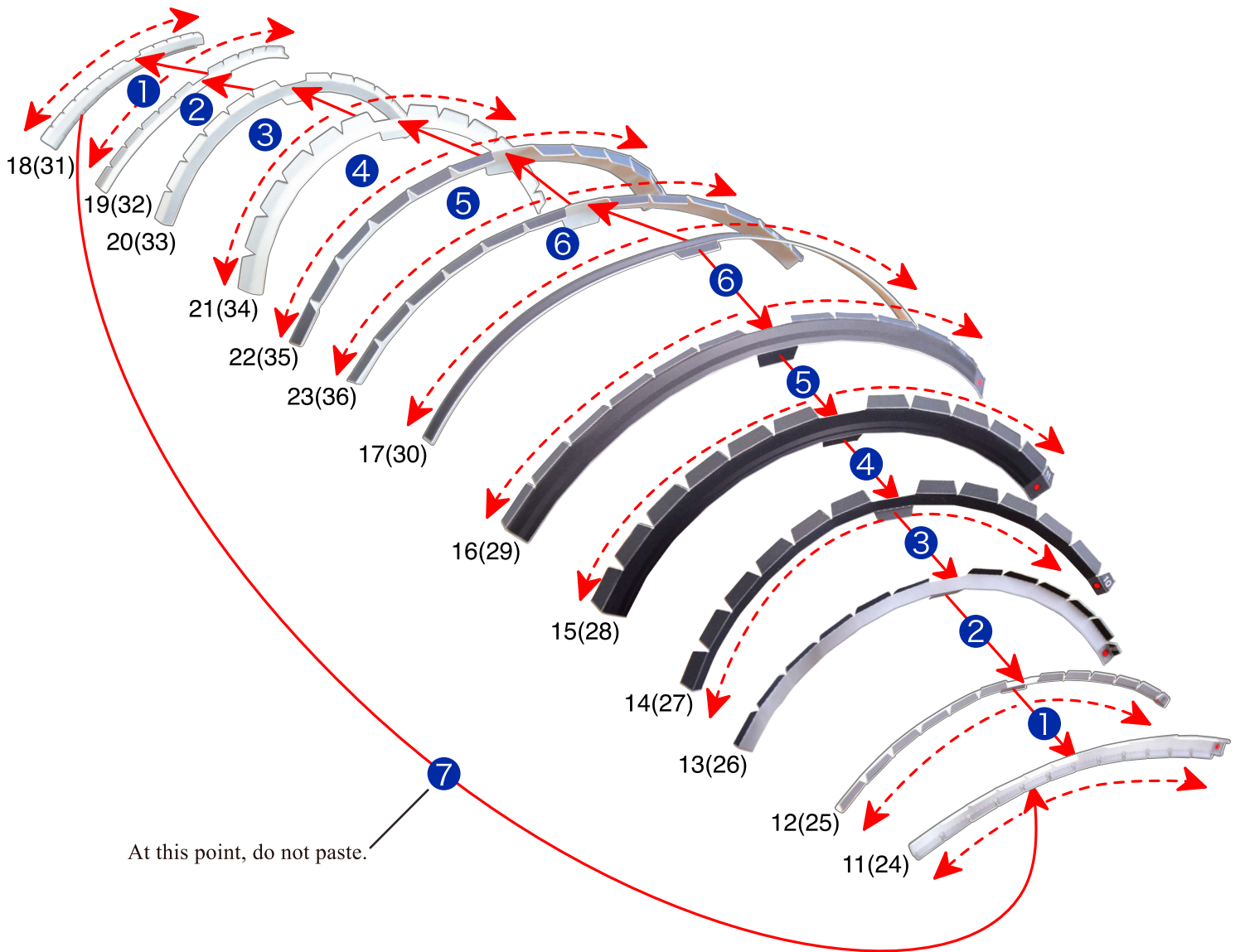

Please refer to the "Basic working method and markings" symbol chart on Page 2 to assemble each part.



Glue in order from 1 to 5 on the graphic.

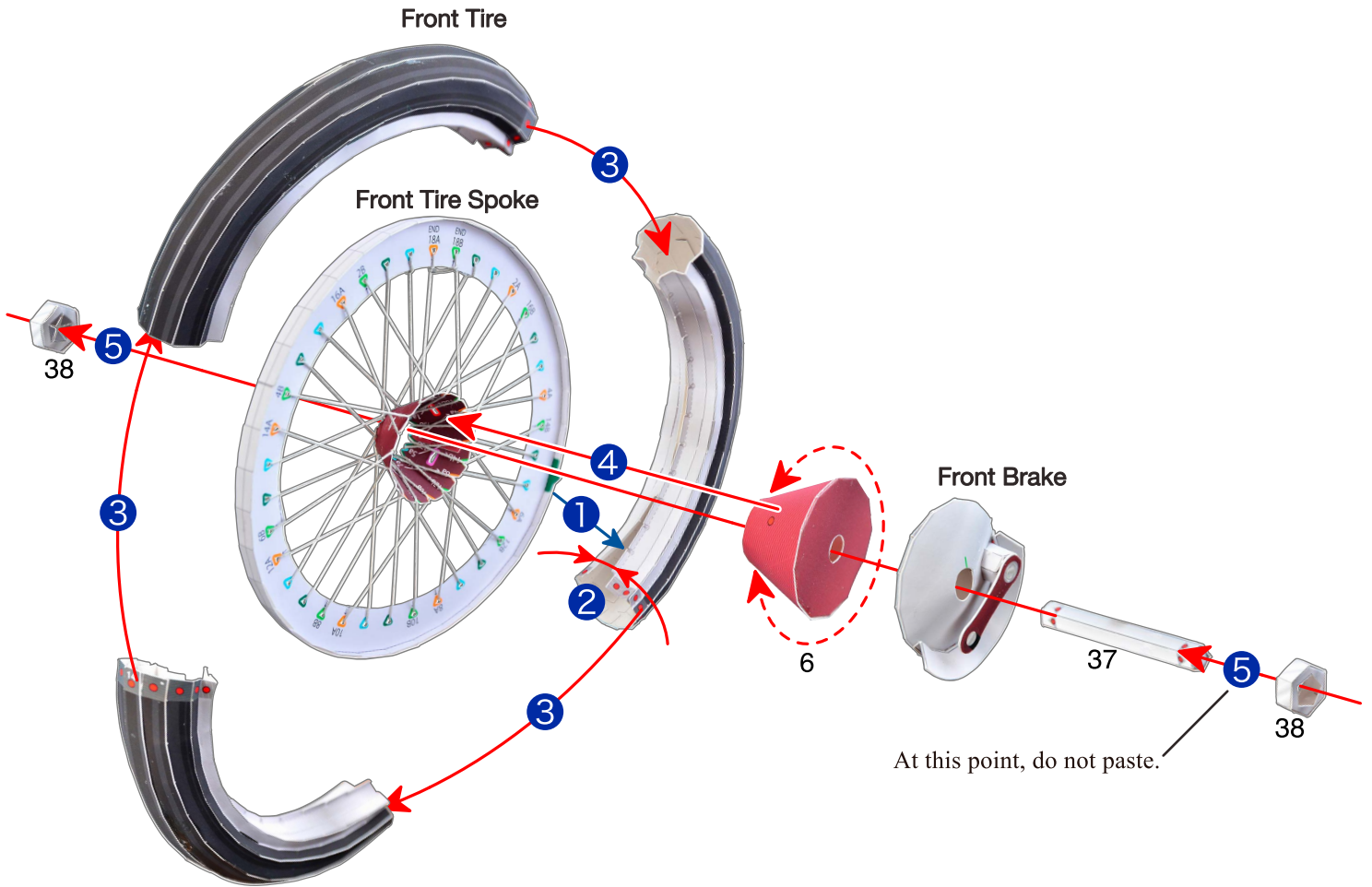

< Reference photo >



3 Assembly of the Rear Tire Spoke

Please refer to the "Basic working method and markings" symbol chart on Page 2 to assemble each part.



Rear Tire Spoke

Glue in order from 1 to 4 on the graphic.

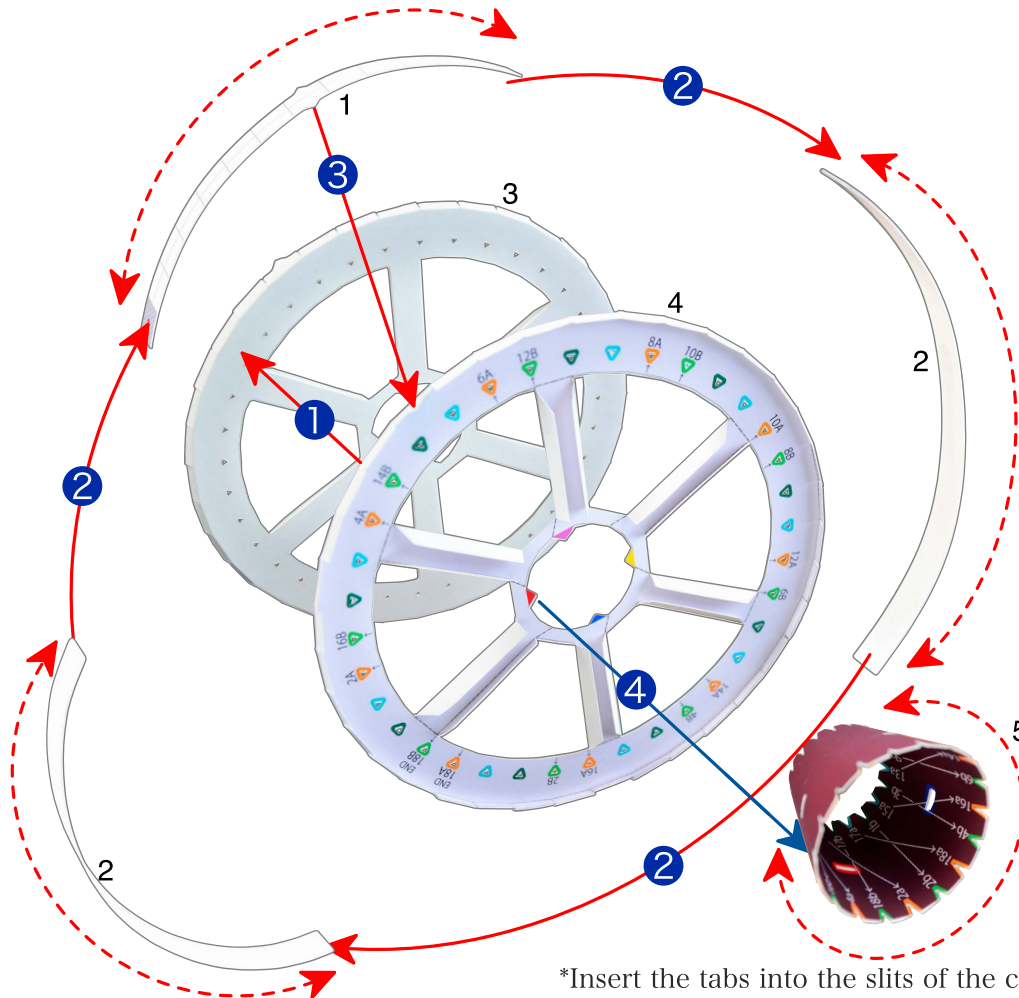

*Insert the tabs into the slits of the corresponding colors.

Rear Brake B

Glue in order from 1 to 6 on the graphic.

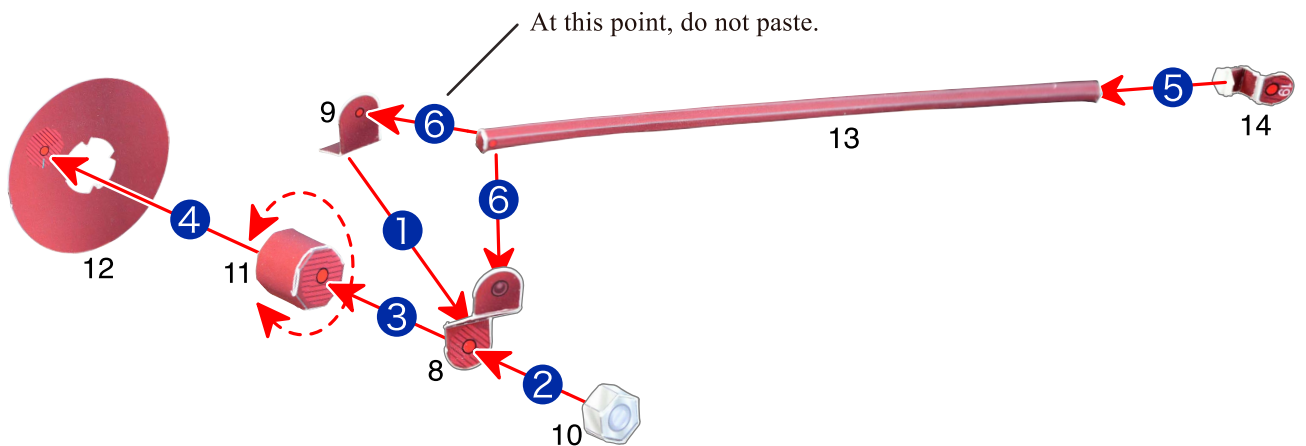

Please refer to the “Basic working method and markings” symbol chart on Page 2 to assemble each part.



Assembly of Spokes - 1 (Section A)

Tie a string to Hole 1A in the rear tire spoke. Lace the string through the spindle via Gutter 1a of the spindle, hook it at Gutter 2a to lace through Holes 2A then 3A. Bring the string to Gutter 3a and lace it through the spindle to Gutter 4a. Repeat this procedure until the string reaches Hole 18A. Tie the string there.

*When you complete Section A, assemble Section B in the same manner.

*String(e.g. an embroidery thread) A couple of approx. 1.5m strings per wheel.

Lacing Procedure for Section A

1A→1a→2a→2A→3A→3a→4a→4A→5A→
5a→6a→6A→7A→7a→8a→8A→9A→9a→
10a→10A→11A→11a→12a→12A→13A→
13a→14a→14A→15A→15a→16a→16A→
17A→17a→18a→18A

Lacing Procedure for Section B

1B→1b→2b→2B→3B→3b→4b→4B→5B→
5b→6b→6B→7B→7b→8b→8B→9B→9b→
10b→10B→11B→11b→12b→12B→13B→
13b→14b→14B→15B→15b→16b→16B→
17B→17b→18b→18B

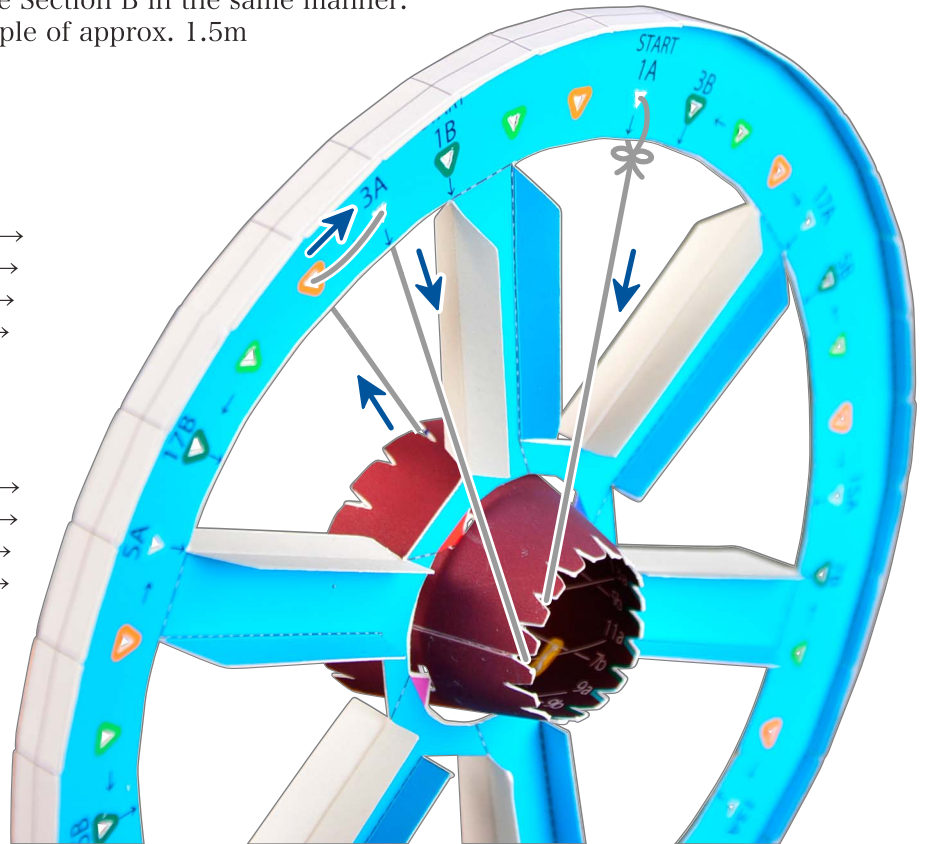

Assembly of Spokes - 2

Once you complete the lacing of Sections A and B, detach the post of the rear tire spoke.

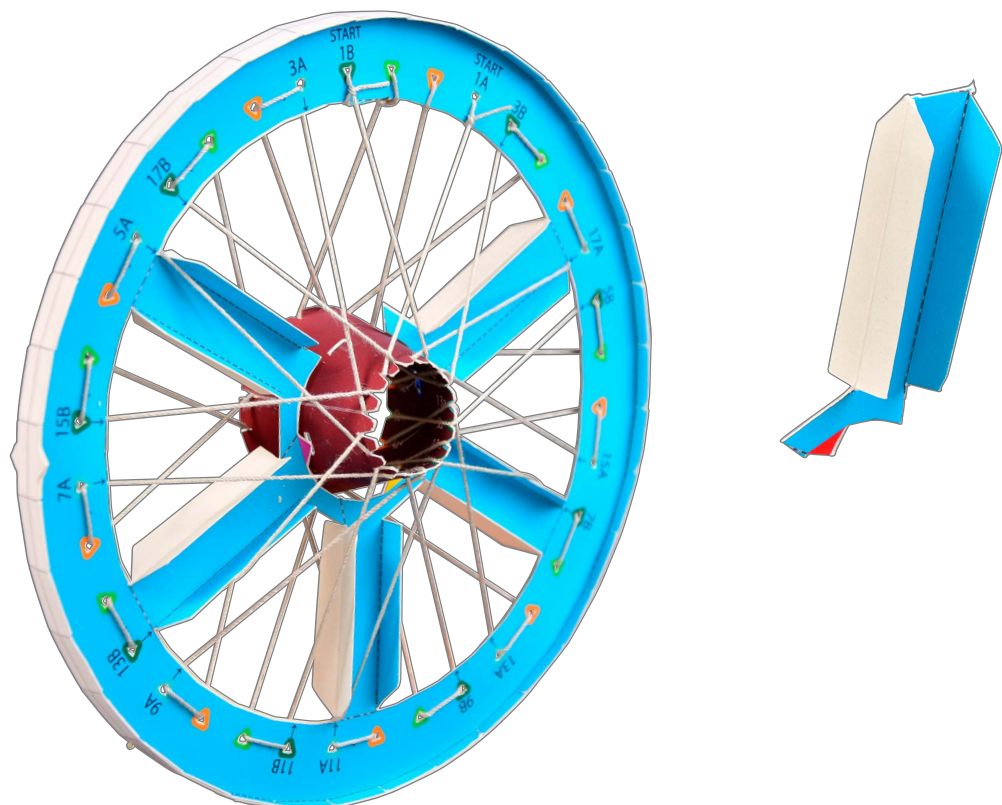

3 Assembly of the Rear Tire

Please refer to the "Basic working method and markings" symbol chart on Page 2 to assemble each part.



Glue in order from 1 to 7 on the graphic.

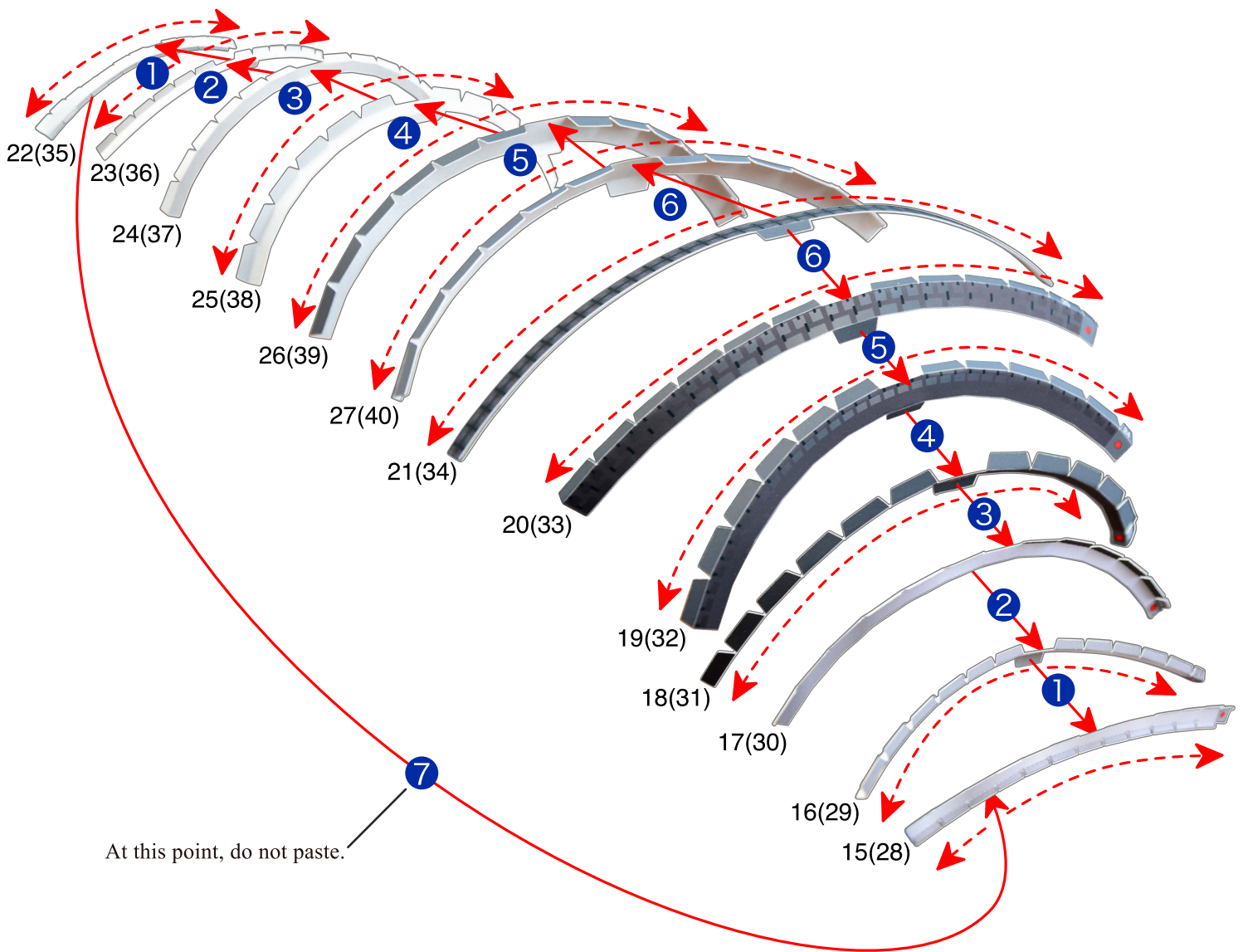

Please refer to the “Basic working method and markings” symbol chart on Page 2 to assemble each part.



Glue in order from 1 to 8 on the graphic.

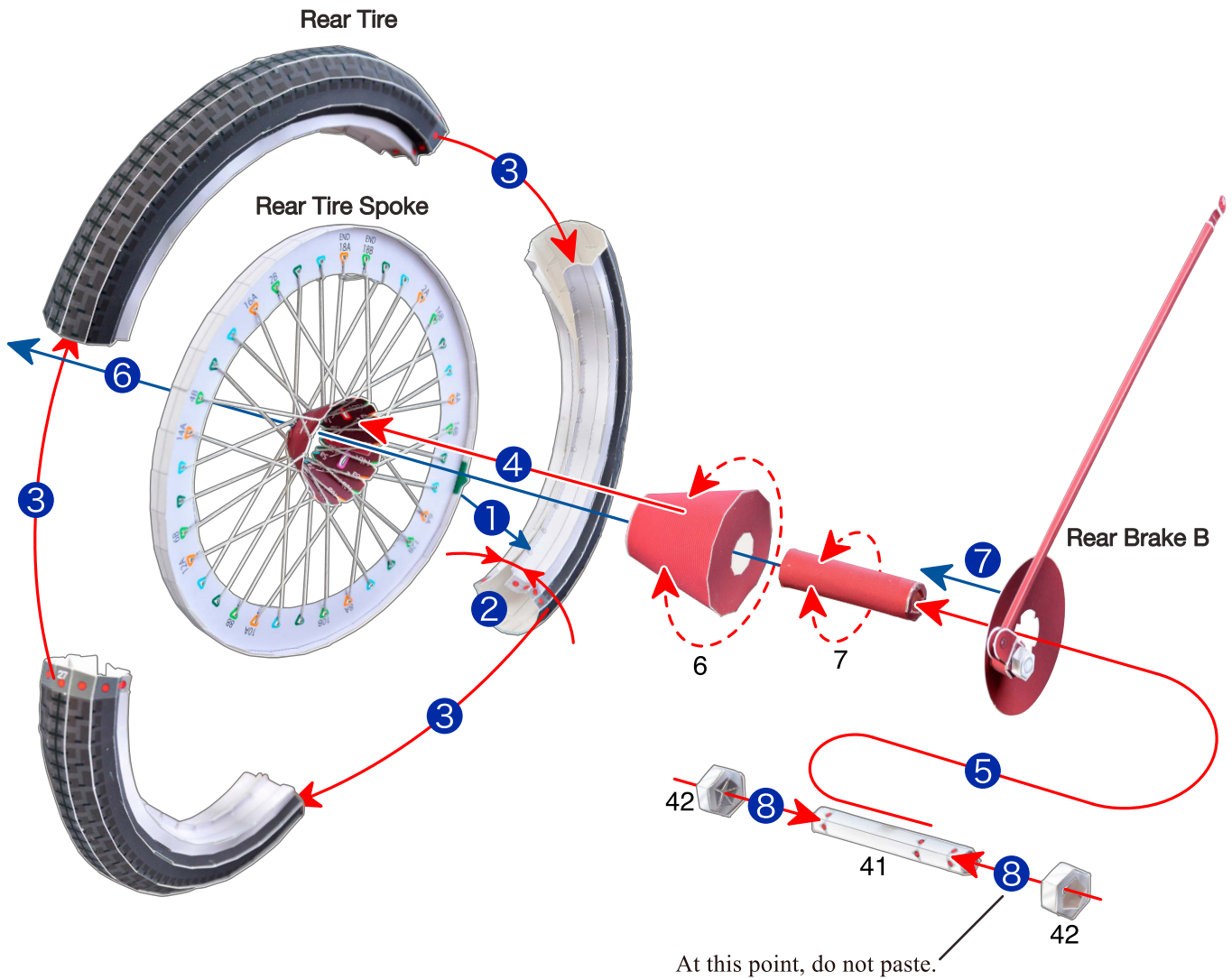

< Reference photo >



4 Assembly of YA-1

Connect each of previously assembled parts in order.

 Fold or Curve

 Glue

 Insert

 Gluing surfaces

1 Glue the rear cushion to the frame.

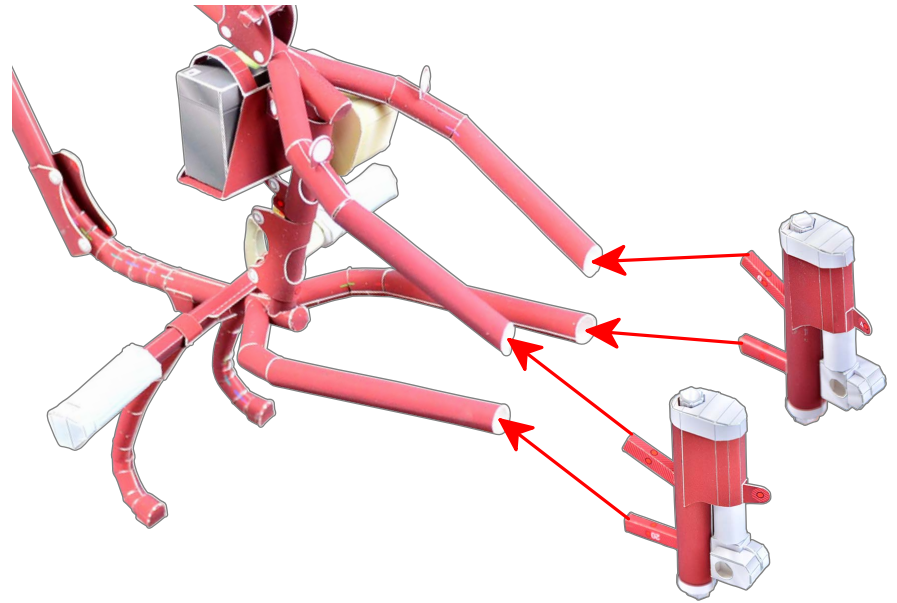

2 Attach the chain to the engine.

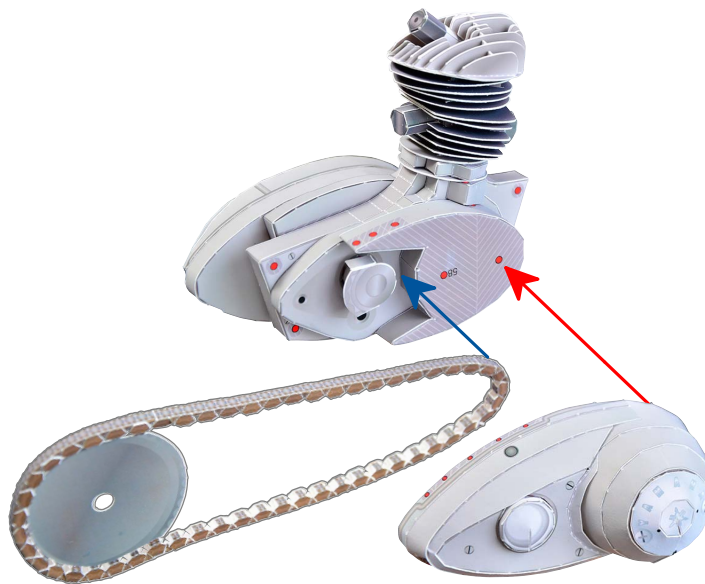

3 Glue the chain cover to the engine.

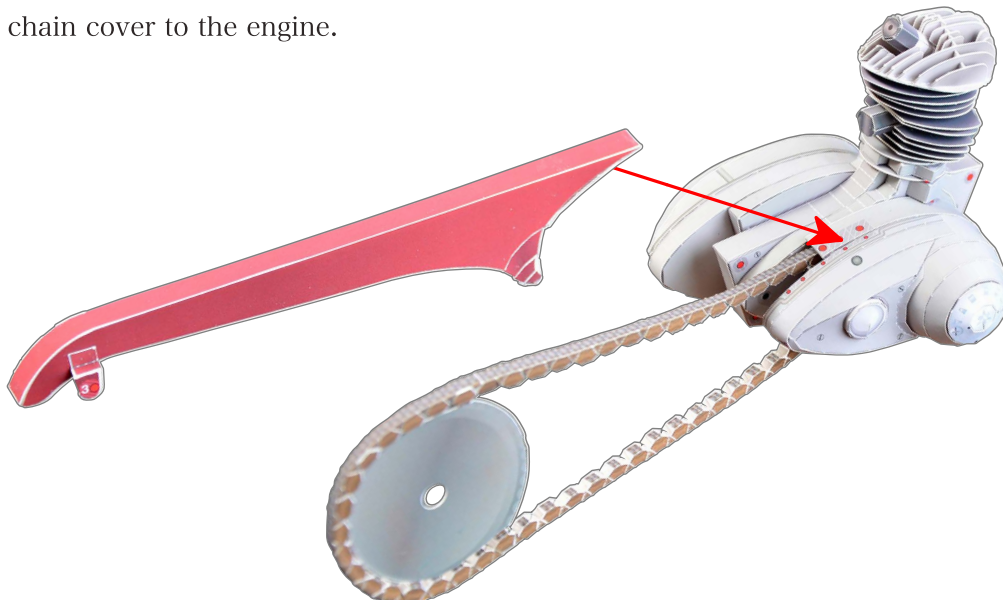

Connect each of previously assembled parts in order.

 Fold or Curve

 Glue

 Insert

 Gluing surfaces

4 Glue the engine to the frame.

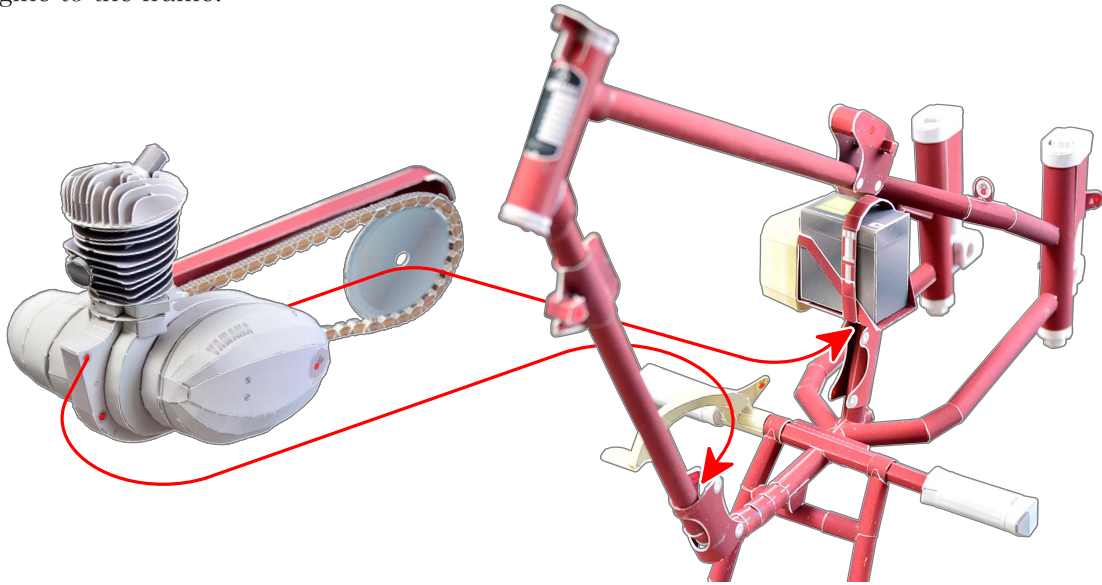

5 Glue the tank to the frame.

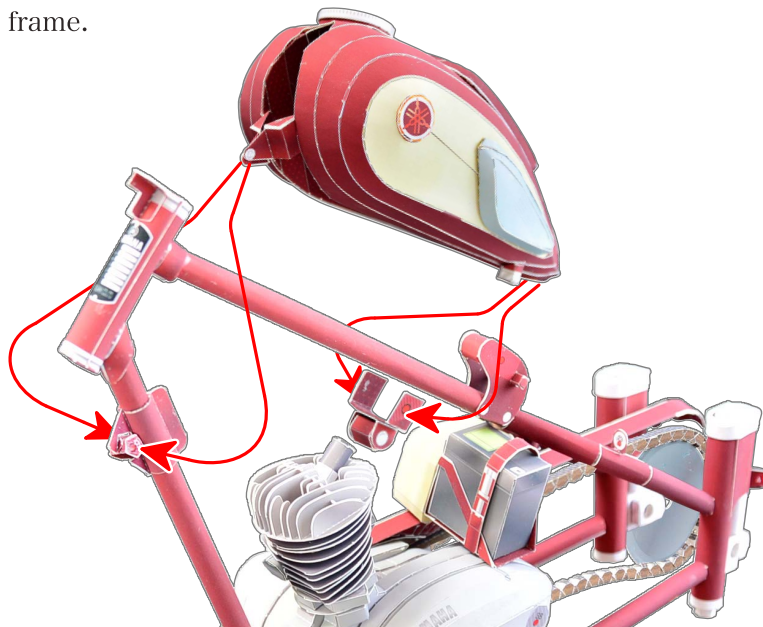

6 Glue the carburetor to the tank and the engine.

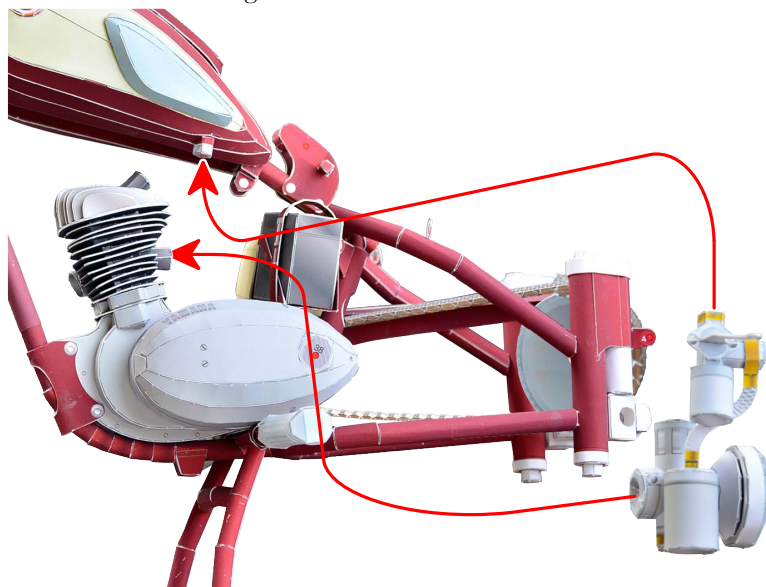

Connect each of previously assembled parts in order.

 Fold or Curve

 Glue

 Insert

 Gluing surfaces

7 Glue the saddle to the frame.

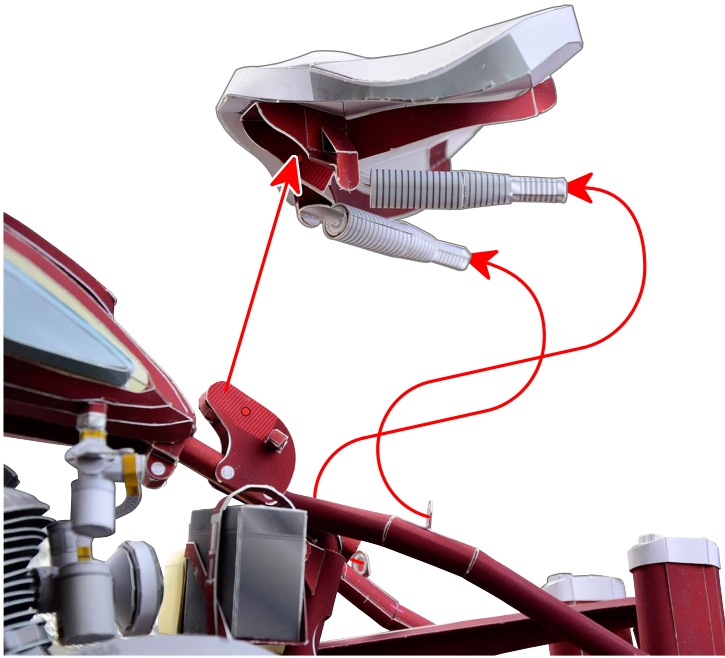

9 Attach the rear tire to the rear cushion.

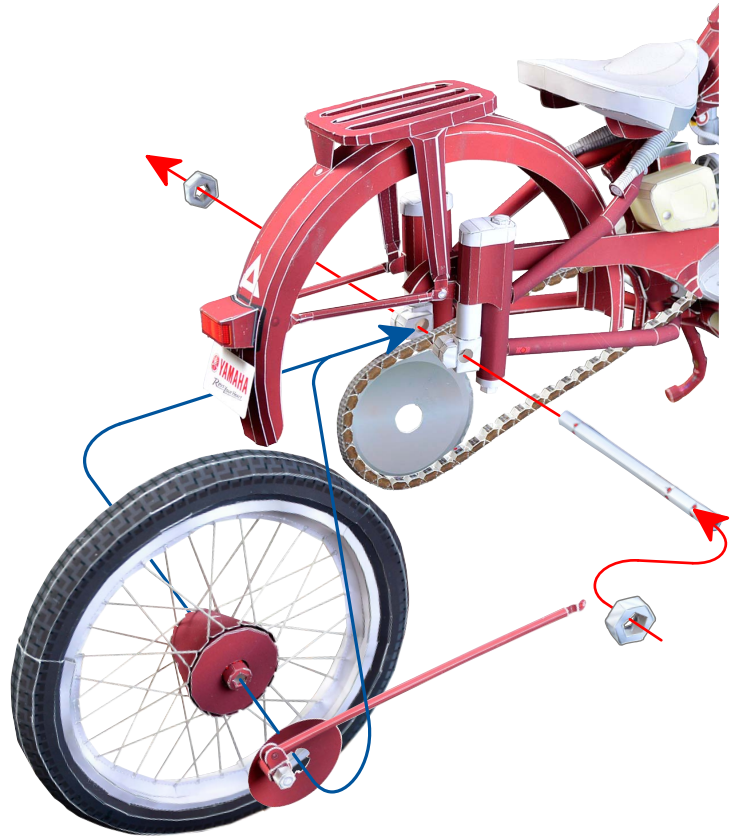

8 Glue the rear fender to the frame and the rear cushion.

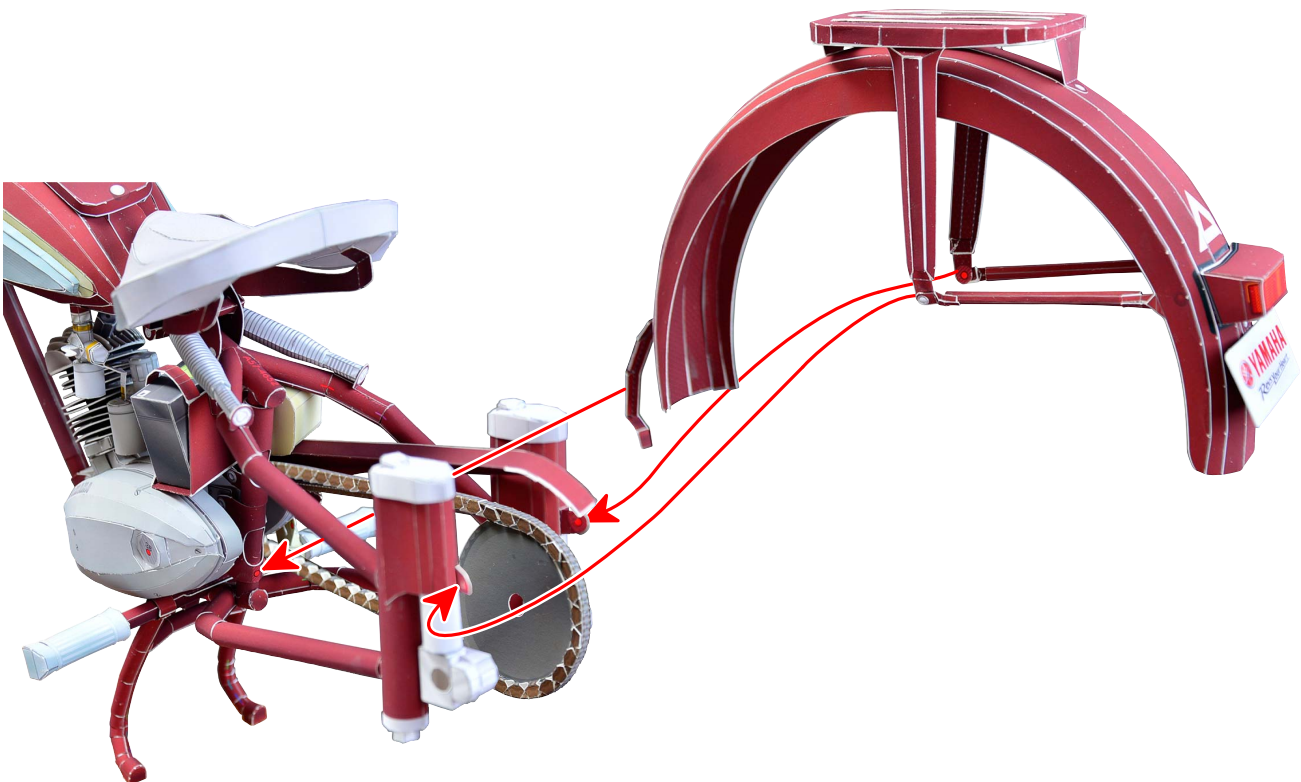

Connect each of previously assembled parts in order.

 Fold or Curve

 Glue

 Insert

 Gluing surfaces

- 10 Glue the muffler to the engine and the frame.
- 11 Glue Rear Brakes A and B.

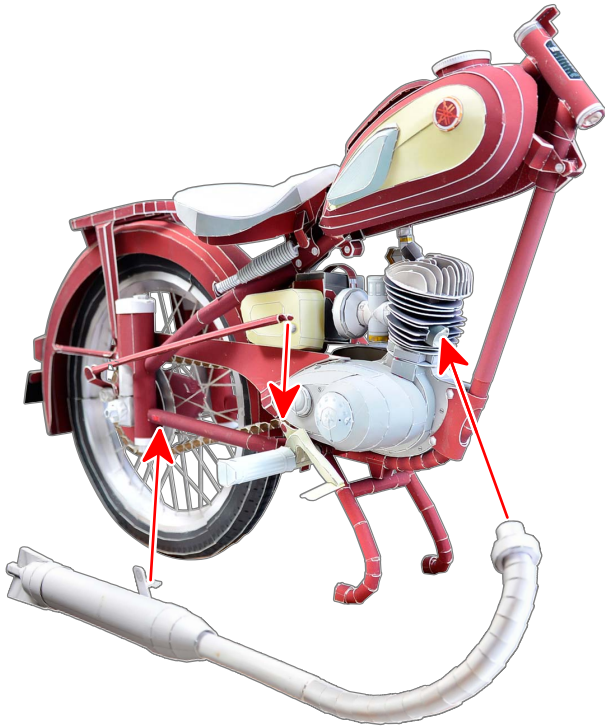

- 13 Glue the front fender to the steering part.

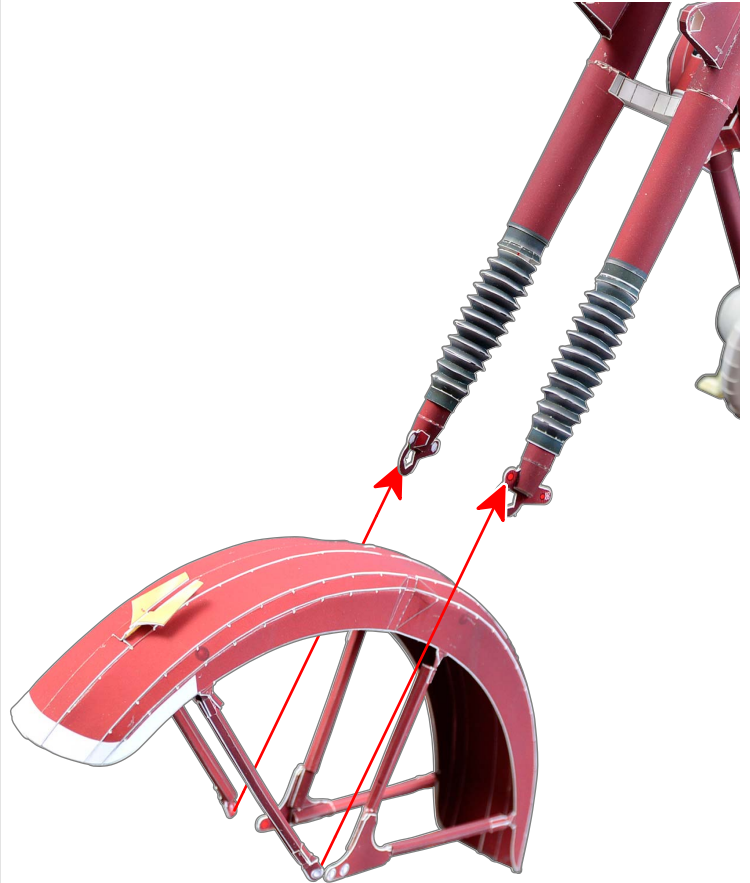

- 12 Attach the steering part to the frame.

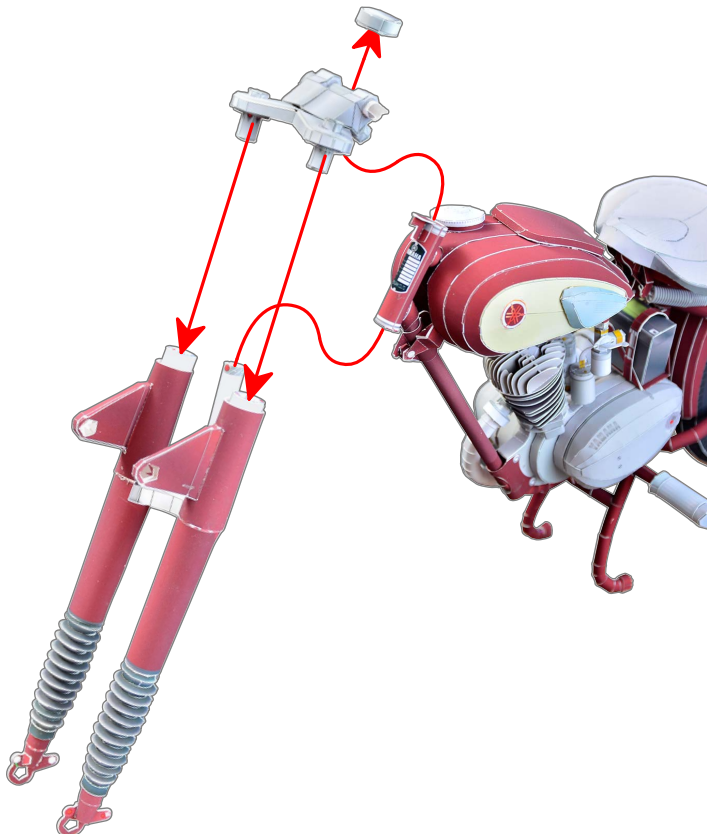

- 14 Attach the front tire to the steering part.



Connect each of previously assembled parts in order.

 Fold or Curve

 Glue

 Insert

 Gluing surfaces

15 Glue the headlight to the steering part.

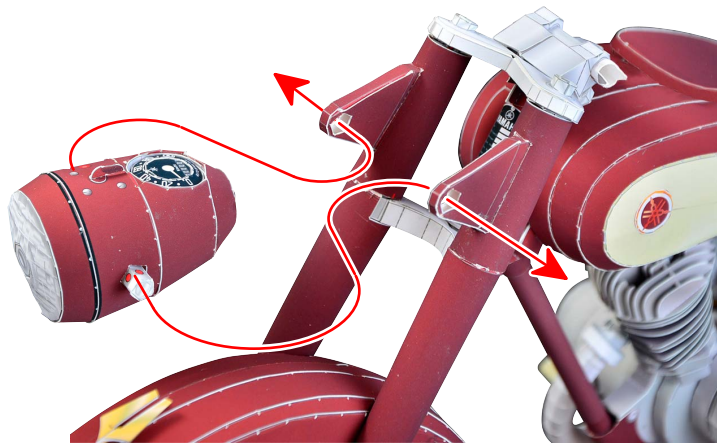

17 Glue the kick pedal and the change pedal to the engine.

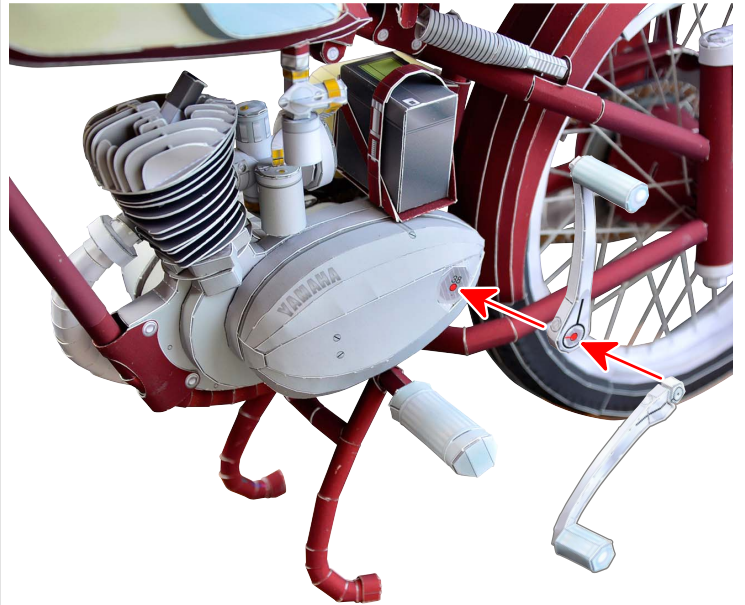

16 Glue Steering Parts A and B to Steering Part C.

Glue in order from 1 to 3 on the graphic.

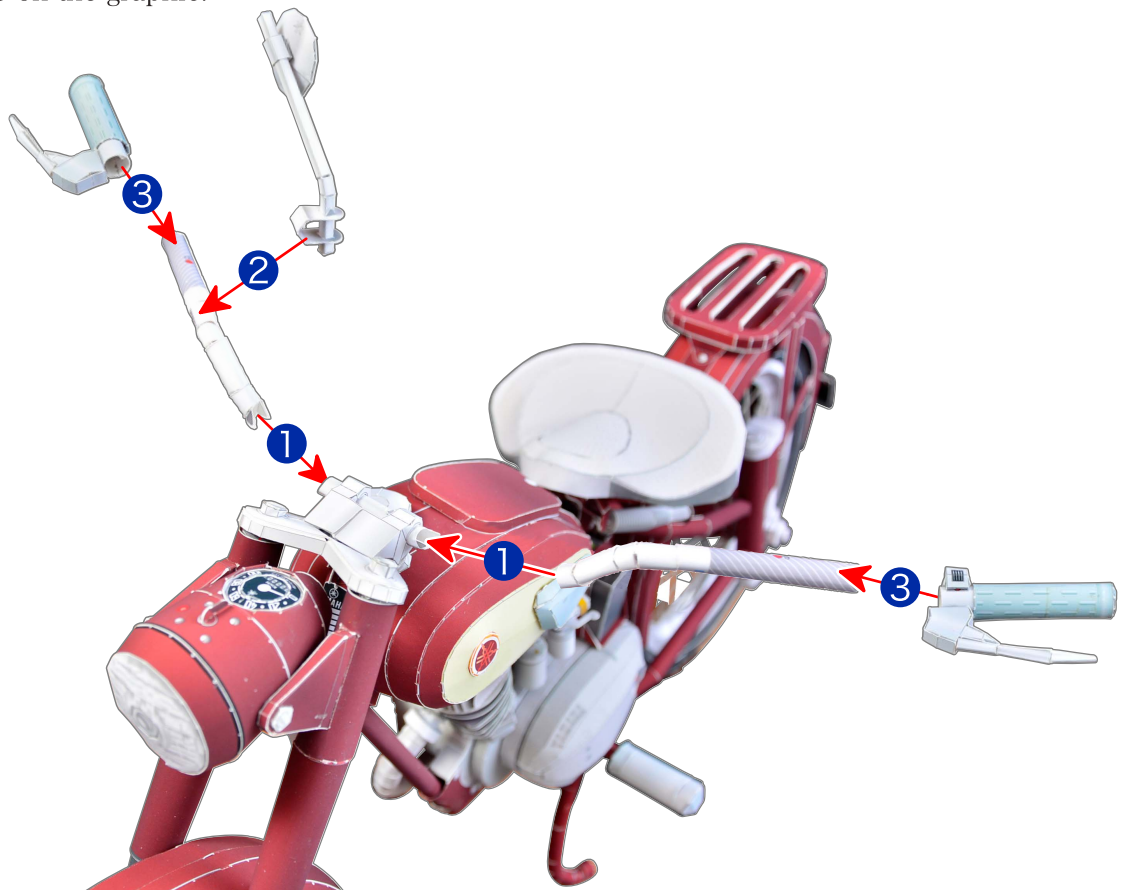

5 Completion

Here are pictures of completed models. Please refer to them when assembling.



5 Completion

Here are pictures of completed models. Please refer to them when assembling.



5 Completion

Here are pictures of completed models. Please refer to them when assembling.

